

atersa



atersa

grupo elecnor

- ES** Módulo Fotovoltaico Profesional
- EN** Professional Photovoltaic Module
- FR** Module Photovoltaïque Professionnel
- DE** Professionelle Photovoltaik-Modul
- IT** Modulo Fotovoltaico Professionale
- NL** Professionele Fotovoltaïsche Module



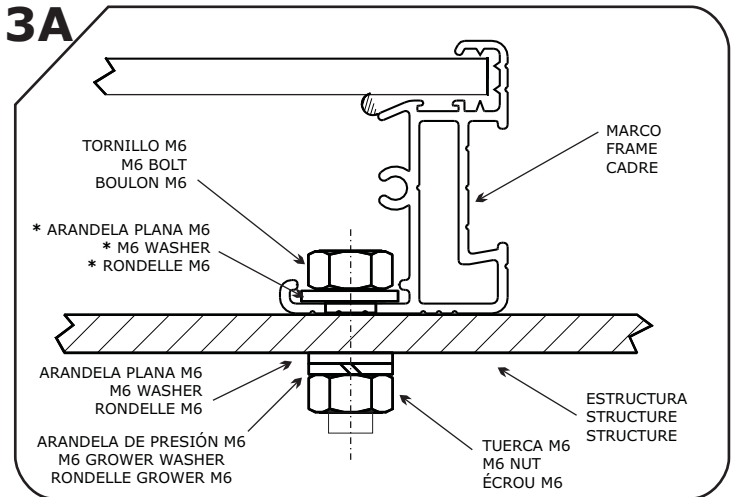
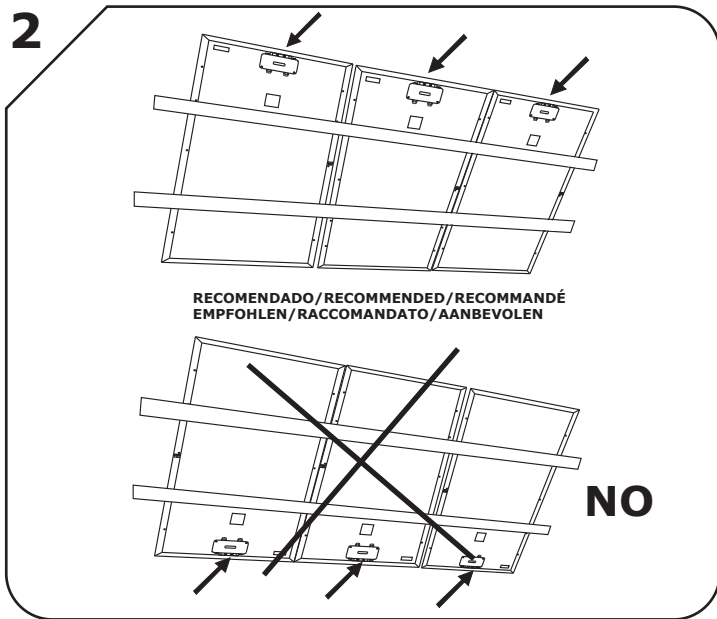
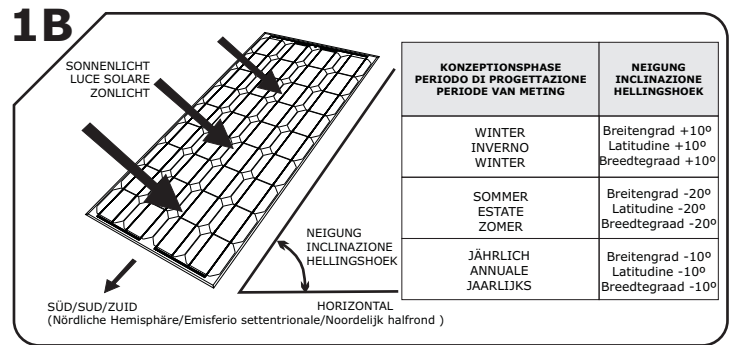
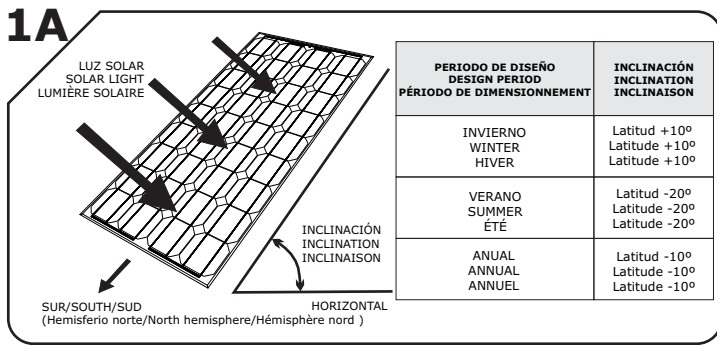

- * **Nota:** Utilizar Arandela M6 DIN 9021 para perfil Hook V4.
Utilizar Arandela M6 DIN 125 para perfil Hook V1.
- * **Note:** Use M6 DIN 9021 washer for Hook V4 profile.
Use M6 DIN 125 washer for Hook V1 profile.
- * **Remarque:** Utiliser des rondelles M6 DIN 9021 pour les profilés Hook V4.
Utiliser des rondelles M6 DIN 125 pour les profilés Hook V1.

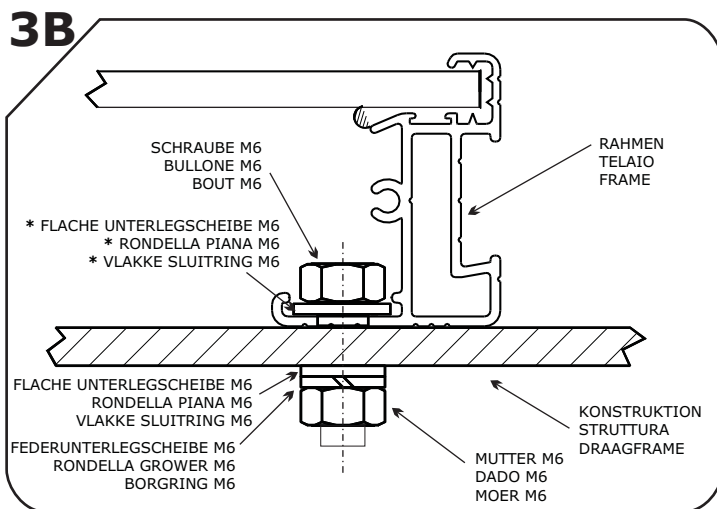

- * **Hinweis:** Verwenden Sie M6 DIN 9021 für das Profil Hook V4.
Verwenden Sie M6 DIN 125 für das Profil Hook V1.
- * **N.B.:** Utilizzare la rondella M6 Din 9021 per il profilo Hook V4.
Utilizzare la rondella M6 DIN 125 per il profilo Hook V1.
- * **Voetnoot:** Gebruik sluitring M6 DIN 9021 voor profiel Hook V4.
Gebruik sluitring M6 DIN 125 voor profiel Hook V1.

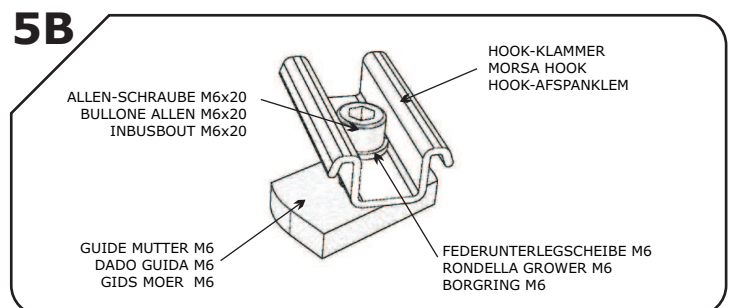
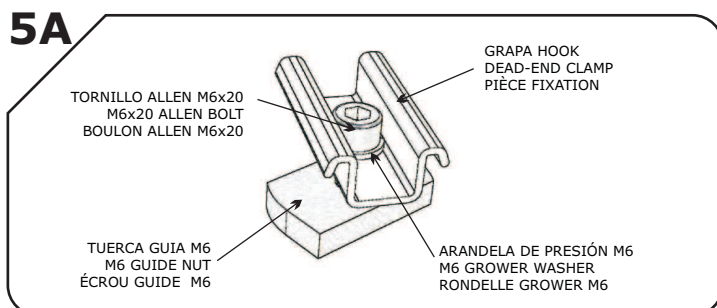
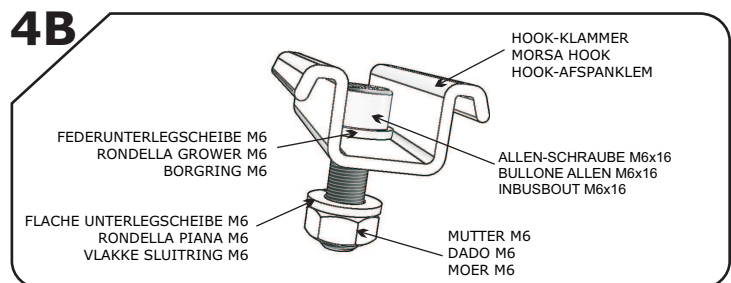
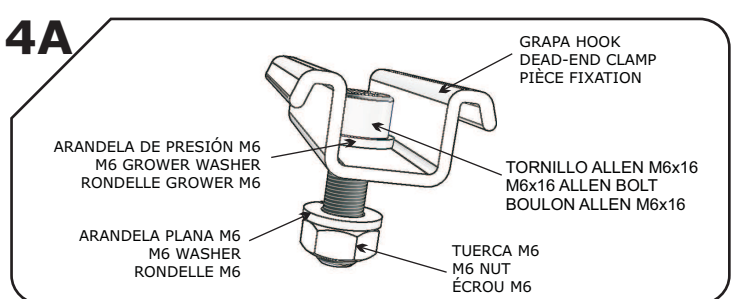

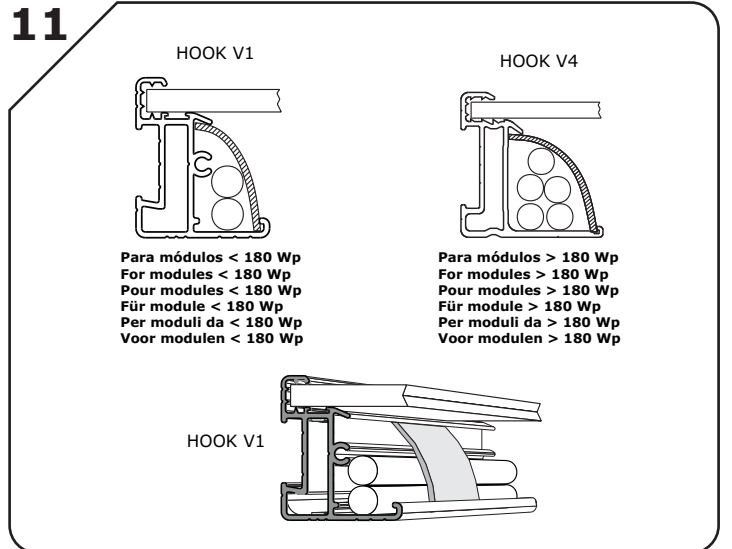
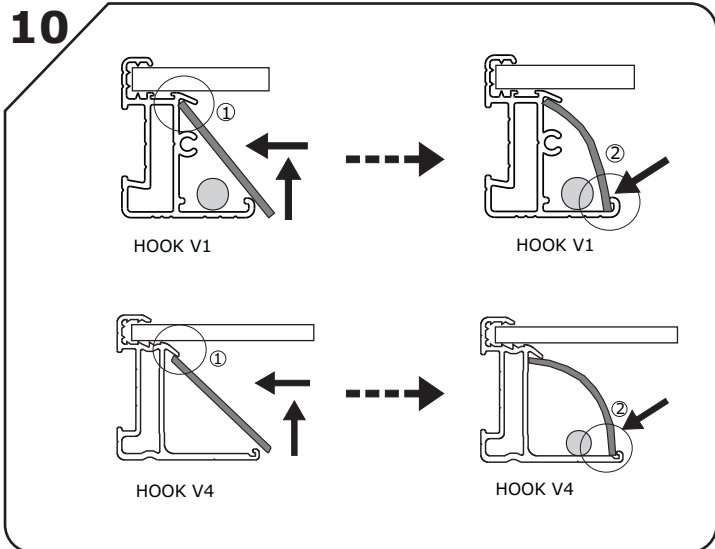
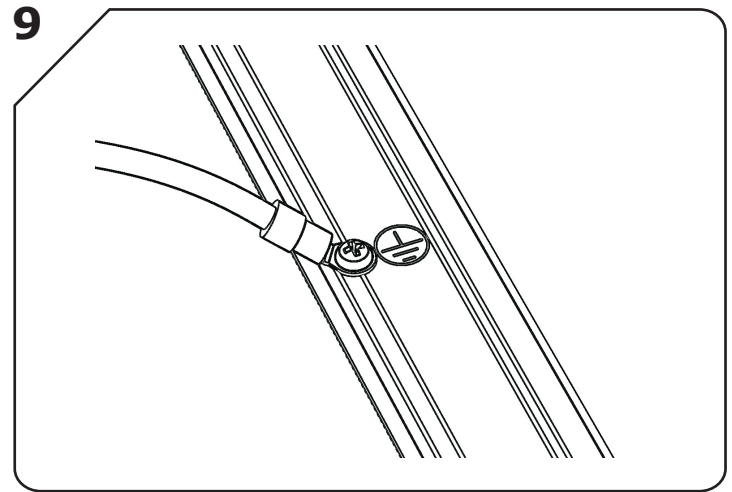
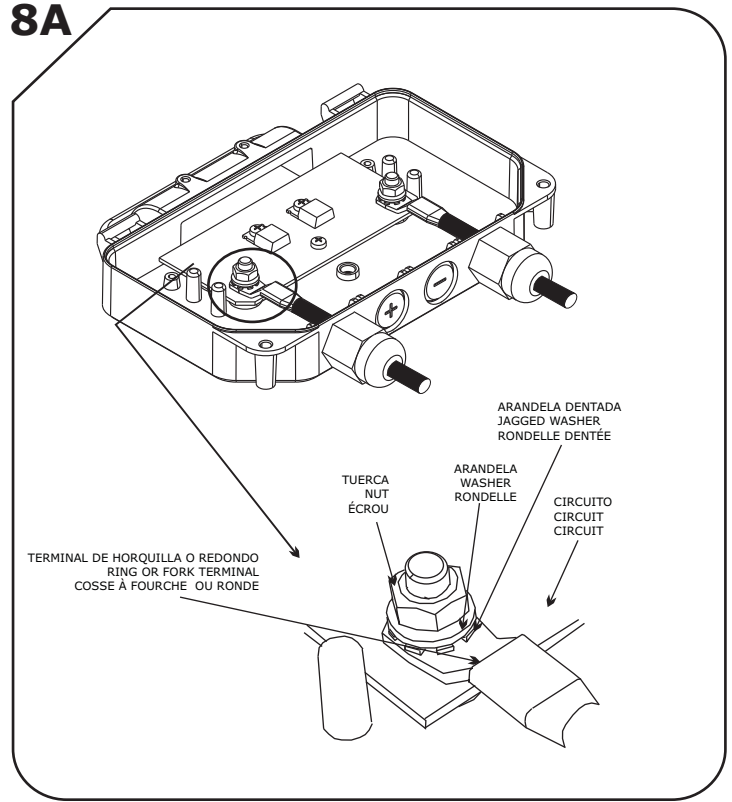
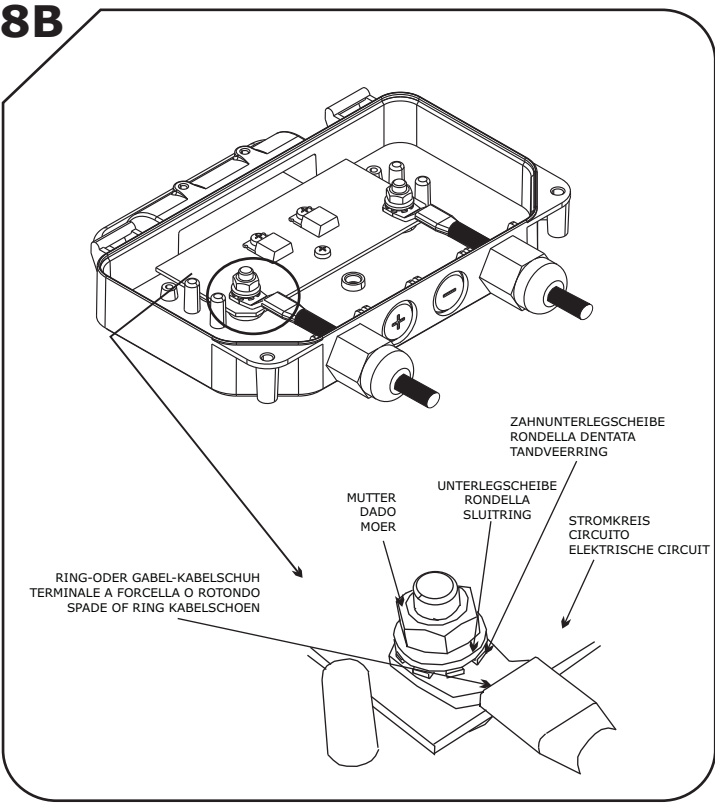
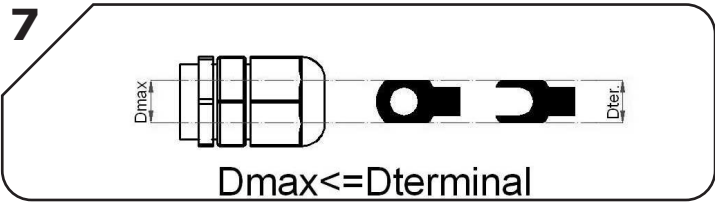
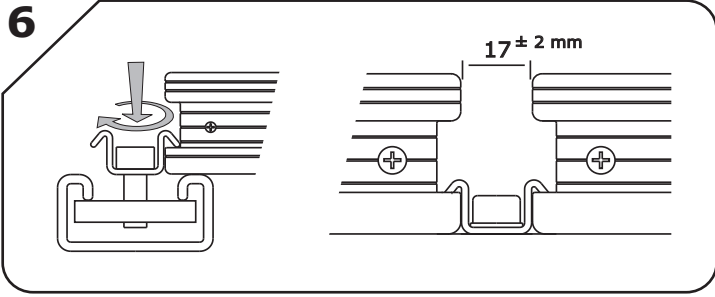

12

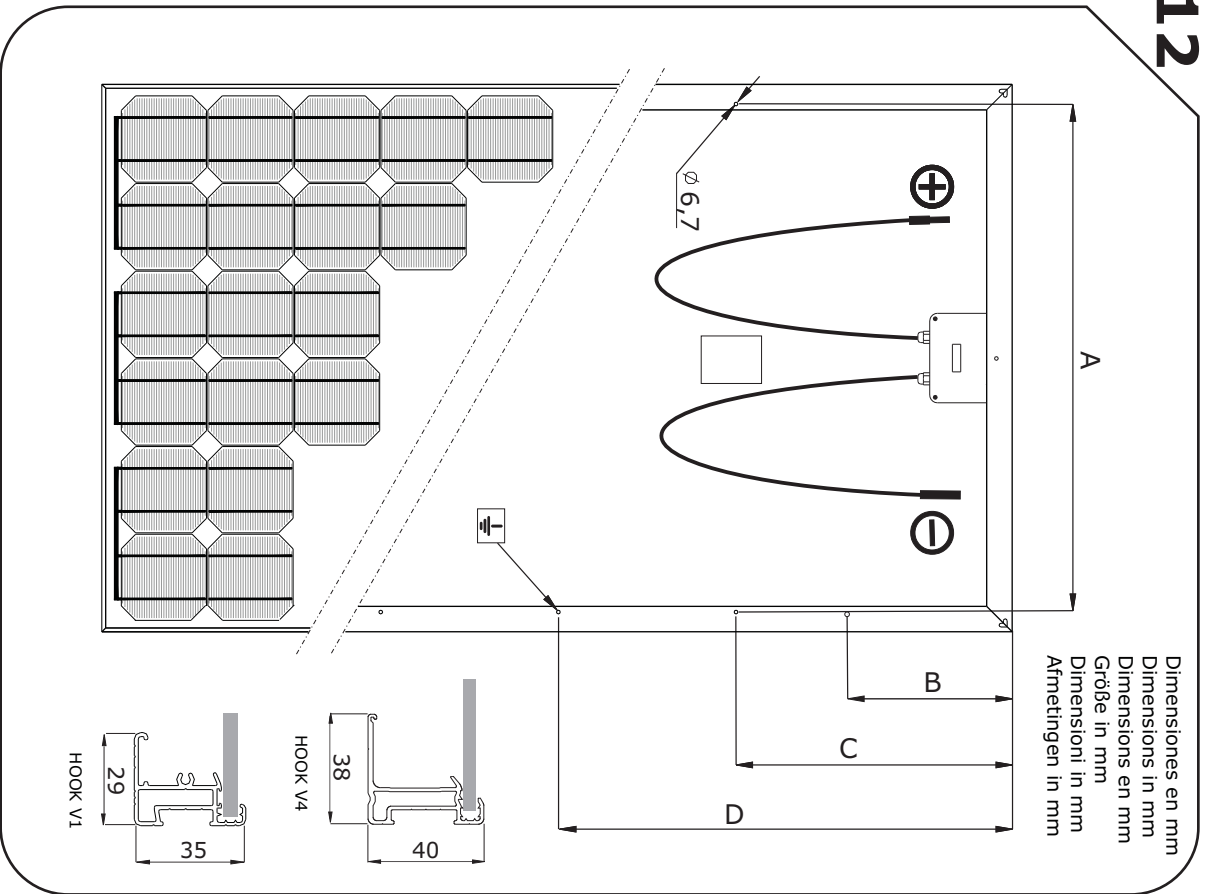

* Las áreas marcadas en el dibujo (A y B) están destinadas a la fijación del laminado y garantizar su correcta instalación.
 Utilizar siempre sistemas de fijación que no dañen al laminado.

* The areas marked in the drawing (A and B) are intended for the fixation of the laminate and ensure proper installation.
 Always use fastening systems that do not damage the laminate.

* Les zones marquées dans le dessin (A et B) sont destinés à la fixation du stratifié et assurer une bonne installation.
 Toujours utiliser des systèmes de fixation qui n'endommagent pas le stratifié.

13

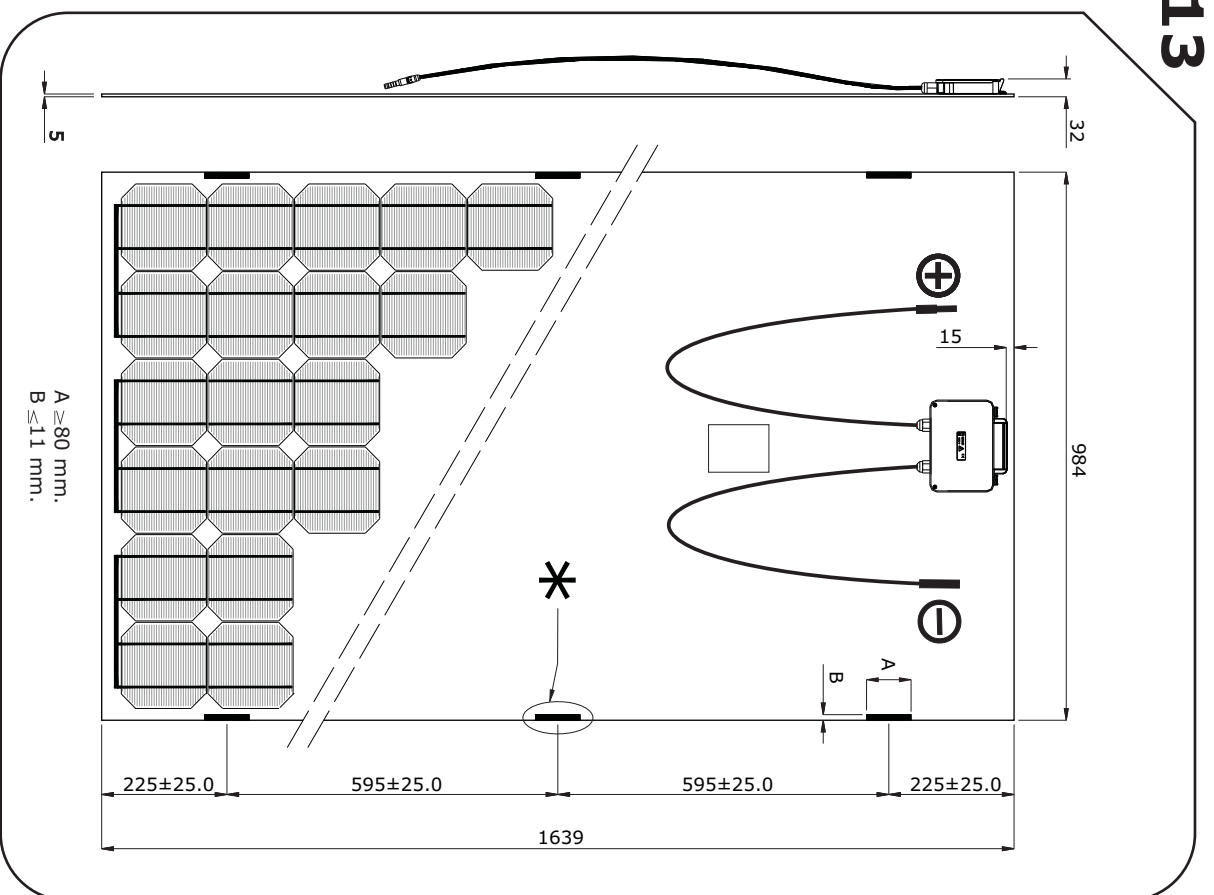

* Die Flächen in der Zeichnung (A und B) sind für die Fixierung des Laminats bestimmt und eine ordnungsgemäße Installation.
 Es sind grundsätzlich Befestigungssysteme zu gebrauchen, die die Laminiierung nicht beschädigen.

* Le aree contrassegnate nel disegno (A e B) sono destinati per il fissaggio del laminato e garantire una corretta installazione.
 Utilizzare sempre sistemi di fissaggio che non danneggino il laminato.

* De gebieden gemarkeerd in de tekening (A en B) zijn bestemd voor de fixatie van het laminaat en zorgen voor een correcte installatie.
 Gebruik altijd een montagesysteem dat het laminaat niet kan beschadigen.